

42 PUMP

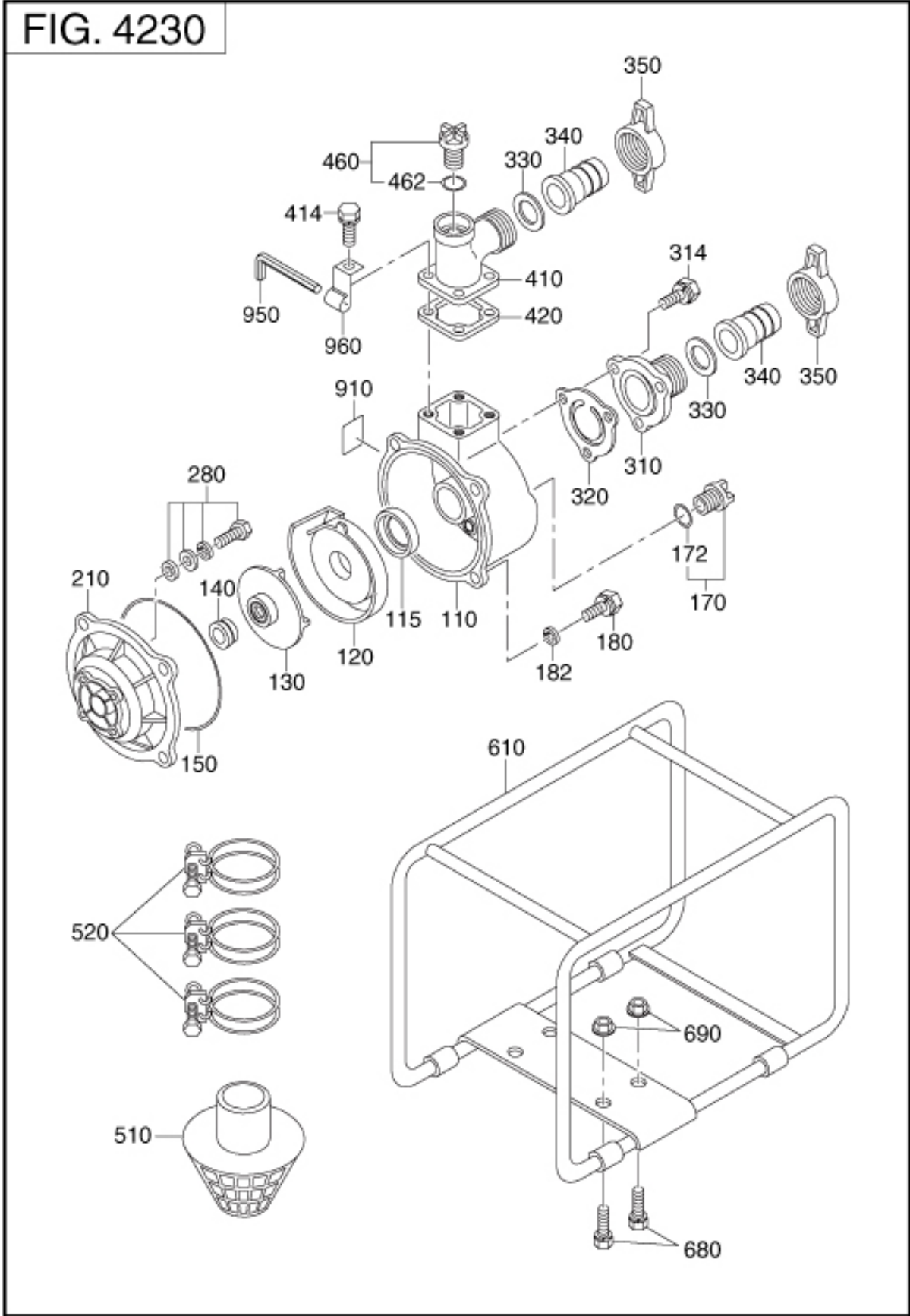

REF.	PART NUMBER	PART NAME	CODE NO.	QTY	REMARKS	INTERCHANGE
110	480-05010-01	CASING	-	1		
115	480-05010-12	PACKING,INNER CASING	-	1		
120	480-05710-11	INNER CASING	-	1		
130	480-05710-09	IMPELLER	-	1		
140	480-05210-08	MECHANICAL SEAL	-	1		
150	480-05010-02	O-RING	-	1		
170	480-05010-21	PLUG,DRAIN	-	1		
172	480-02510-40	O RING,DRAIN BOLT	-	1		
180	480-05710-99	SOCKET BOLT	-	4		
182	481-00001-71	SPRING WASHER	-	4		
210	480-05010-04	CASING COVER	-	1		
280	480-05010-05	CASING BOLT AY	-	4	M8X50	
310	480-05010-13	SUCTION FLANGE	-	1		
314	480-05010-14	HEX BOLT	-	3	M8X25	
320	480-05010-15	CHECK VALVE	-	1		
330	480-05010-17	PACKING,COUPLING	-	2		
340	481-00001-14	HOSE COUPLING	-	2		
350	481-00001-15	COUPLING HANDLE	-	2		
410	480-05010-19	DELIVERY FLANGE	-	1		
414	480-05010-14	HEX BOLT	-	4	M8X25	
420	480-05010-20	PACKING	-	1		
460	480-05010-21	PLUG,DRAIN	-	1		
462	480-02510-40	O RING,DRAIN BOLT	-	1		
510	480-05750-29	STRAINER	-	1		
520	480-05010-28	HOSE BAND	-	3		
610	481-00000-44	PIPE FRAME	-	1		
680	480-05010-23	HEX BOLT	-	4	M8X40	
690	480-05010-24	FLANGE NUT	-	4	M8	
950	480-05710-92	HEX SOCKET SCREW	-	1		
960	480-05710-21	HOOK	-	1		